

REV.	DESCRIPTION	DATE	BY

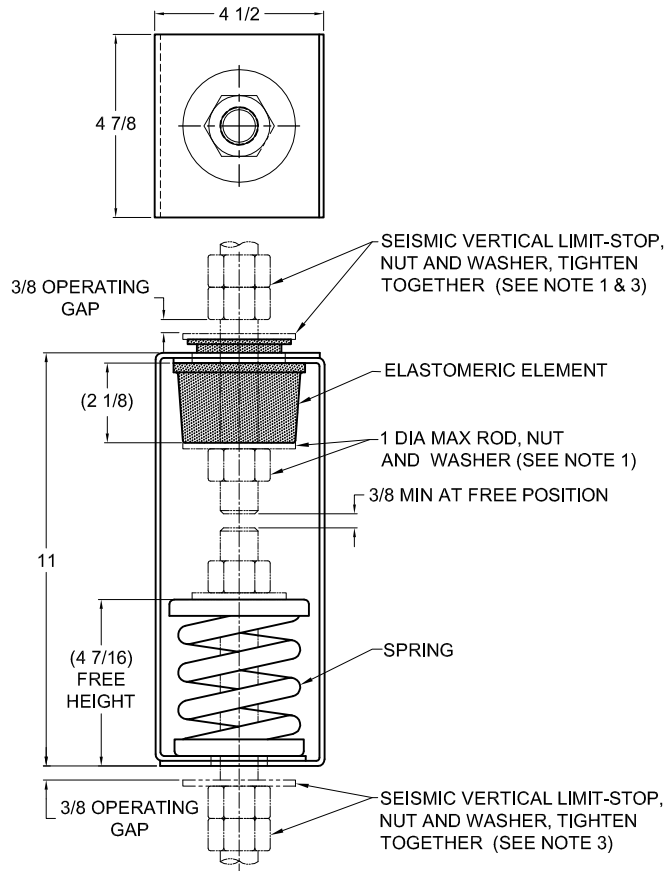

TYPE HRS-1E-D PRE-COMPRESSED ELASTOMERIC & SPRING HANGERS FOR 1" NOMINAL DEFLECTION					
HANGER	RATED LOAD (LBS)	DEFLECTION (IN)	SPRING RATE (LB/IN)	SPRING COLOR CODE	ELEMENT LOAD & COLOR CODE
HRS-1E-D400PR	400	1.70	303	BLACK	RE-D-750 BLACK
HRS-1E-D650PR	650	1.44	619	RED	RE-D-750 BLACK
HRS-1E-D825NPR ¹	825	1.56	771	RED/DK BLUE	RE-D-750 BLACK
HRS-1E-D1000PR	1000	1.37	1000	TAN	RE-D-1350 RED
HRS-1E-D1400PR	1400	1.52	1400	PINK	RE-D-1350 RED
HRS-1E-D2000PR	2000	1.62	1800	WHITE	RE-D-1900 GREEN

NOTES:
 1. TWO NESTED SPRINGS YIELD THIS LOAD. THE COLOR CODE INDICATED IS FOR OUTER SPRING/ INNER SPRING.

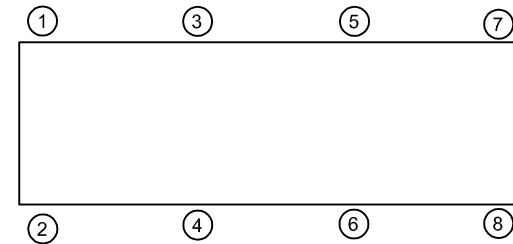

ISOLATOR SELECTIONS	
LOC 1:	LOC 2:
LOC 3:	LOC 4:
LOC 5:	LOC 6:
LOC 7:	LOC 8:
CUSTOMER EQP'T. TAG:	

NOTE: MATERIAL SHOWN IS FOR (1) SET.

- NOTES:
- HANGER RODS, NUTS AND WASHERS, AS SHOWN, NOT BY THE VMC GROUP.
 - STANDARD FINISH: HANGER BOX - PAINTED, POWDER COATED OR GALVANIZED STEEL, SPRING - POWDER COAT.
 - SEISMIC VERTICAL LIMIT-STOP HARDWARE REQUIRED FOR SEISMIC APPLICATIONS.
 - ALL DIMENSIONS IN INCHES. INTERPRET PER ANSI Y14.
 - ALL DIMENSIONS ARE FOR REFERENCE, DIMENSIONS SHOWN AS NOMINAL.
 - ALL SPRINGS ARE DESIGNED WITH MINIMUM 50% OVER-TRAVEL.
 - HANGER BOXES ARE AVAILABLE PRE-COMPRESSED UP TO THEIR DESIGNATED MAX. LOAD. PERCENTAGE OF PRE-COMPRESSION TO BE DETERMINED BY ENGINEERED APPLICATION OR AS REQUESTED BY CUSTOMER AT TIME OF ORDER. CONSULT FACTORY FOR POSSIBLE ADDITIONAL PARAMETERS AND OR LIMITATIONS.
 - HANGER BOXES WITH AN ELASTOMERIC ELEMENT HAVE UP TO AN ADDITIONAL 1/2" NOMINAL DEFLECTION.
 - DOUBLE LOWER NUT PROVIDED.
 - ROD EXTENSION BELOW LOWER NUT EXTENDS (1.5XROD DIA.) AS SHIPPED.
 - PRE-COMPRESSED 50% OF SPRING RATED DEFLECTION.
 - RATED DEFLECTIONS ARE WITHIN 25% OF NOMINAL. HIGHER DEFLECTIONS ARE ALLOWED IF THEY MEET SPECIFICATIONS.

OTHER MATERIALS, COMPOUNDS, OR FINISHES WITH EQUAL OR SUPERIOR PROPERTIES MAY BE SUBSTITUTED AS THEY BECOME AVAILABLE.

CERTIFIED FOR:

JOB NAME: _____

CUSTOMER : _____

CUSTOMER P.O.: _____

SALES ORDER: _____

MODEL HRS-1E-D 400-2000 LBS.
 PRE-COMPRESSED
 ELASTOMERIC AND SPRING HANGERS
 1 INCH DEFLECTION

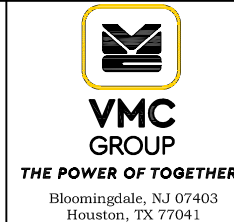

SCALE : NONE

SHEET: 1 OF 1

DRAWING NO.: _____

REVISION _____

Member VISCMA